

INSTALLER GUIDE

LPG (PROPANE) CONVERSION KIT 0595221.

About this kit

- This conversion kit is supplied in two packs. Pack 'A' is for use with metal burners. Pack 'B' is for use with burners that have a ceramic top surface.
- Examine the burner on the gas fire and decide which pack to use.
If using pack 'A' dispose of pack 'B'.
If using pack 'B' dispose of pack 'A' and this installer guide. Pack 'B' contains a set of instructions.

Contents: -

Description	Spares Number	Quantity	Reference
Pilot injector	5108552	1	Copreci RBM 180 -02 (Stamped 225)
Injector alignment gauge	5108895	1	
Burner assembly	5109353	1	
Injector and carrier assembly	5108996	1	(Injector stamped 128)
Data plate label	5108644	1	

Always turn off the gas supply and allow the appliance to cool completely before commencing any servicing. (The inlet 'T' connector for this appliance incorporates an isolating valve).

Installing the kit

Pilot injector. See figure 1.

You may note that the installer guide supplied with the gas fire states that the pilot must be replaced as a whole assembly and that its individual components are not separately replaceable. When fitting this conversion kit this can be ignored.

1. Support the pilot injector. Unscrew and remove the pilot pipe from the pilot assembly.
2. Support the pilot body. Unscrew and remove the pilot injector.
3. Fit the LPG pilot injector contained in pack 'A'.
4. Re-connect the pilot pipe.

Burner and injector

1. Remove the LPG injector and burner from pack 'A'. Screw the LPG injector into the LPG burner.
2. Replace the natural gas burner with the LPG burner. For instructions, please refer to the 'Servicing and parts replacement' section of the installer guide supplied with the appliance.
3. The kit contains an injector alignment gauge. It is important that this gauge is used to ensure that the injector is correctly aligned with the burner. Failure to check may

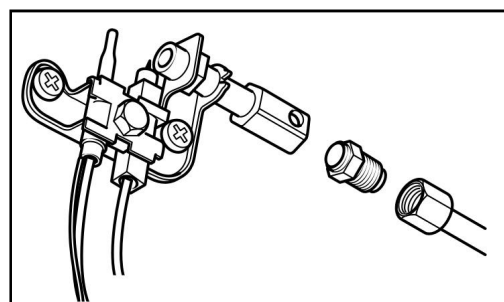

Figure 1. Pilot

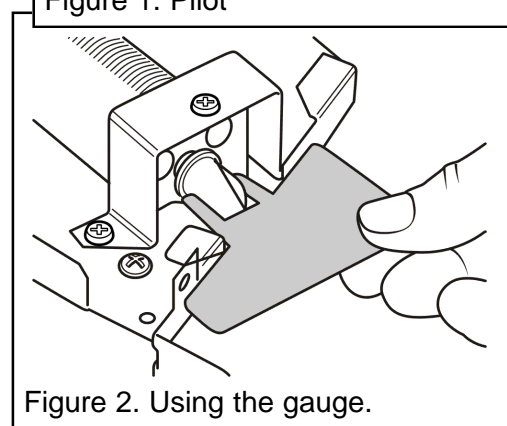

Figure 2. Using the gauge.

result in poor combustion. After fitting the LPG burner place the gauge into the cut out at the side of the burner tray. The slot in the gauge should surround the injector as in figure 2. If the gauge will not fit, the injector alignment will require correction. To do this, support the top of the injector and gently rotate it. Continue to rotate and check with the gauge until correct.

Data label

I. The data plate is located below the burner. The data label supplied in the kit must cover the relevant / similar information only. Peel off the backing on the LPG data label supplied in pack 'A'. Place this on top of the relevant area of the data plate.

Important: Always ensure gas soundness, sealing, spillage test and performance are satisfactory in accordance with installer guide supplied with the appliance and with current regulations.